

AERO

International Aviation
Trade Show & Convention



EXPO®

Toluca, Mexico
March 4th to 6th, 2025



With the support of:



AEROPUERTO
INTERNACIONAL
DE TOLUCA

INFO AVIACION®

The authentic business event for Mexican civil aviation

AeroExpo, the International Aviation Trade Show & Convention, created stands out as the most important civil aviation event in Latin America by effectively sustaining and encouraging the aeronautical business environment in this region.

AeroExpo is here to help you build new and productive business relations, to strengthen your corporate image and to promote products and services exchange at the best cost/benefit among our exhibitors list as well as quality professional visitors.



AeroExpo takes place in Toluca, Latin America's core in corporate aviation, holding the largest fleet and the largest number of executive aviation professionals in the Spanish-speaking world.



AeroExpo is designed by aviation businessmen for aviation businessmen and has over 25 years of experience and tradition.

OPTIONS TO PARTICIPATE

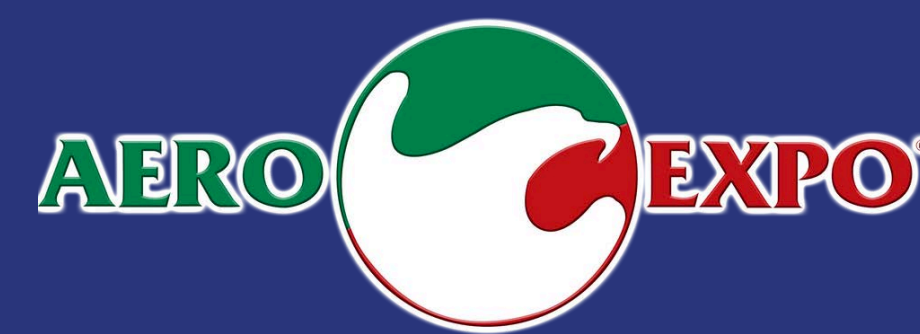

(Prices are in dollars, added value tax included)

Booths 9.8 x 9.8 ft / 96 ft²

Basic Booth



\$3,200 USD

Booth + Aircraft



\$4,400 USD

Booth option include:

- Perimeter screens.
- Monophasic outlet.
- A ledge with the company's name.
- 1 table, 2 chairs and 1 garbage bin.
- 5 name badges for the exhibitors.

Isles 19.6 x 19.6 ft / 384.1 ft²

Basic Isle



\$7,200 USD

Isle + Aircraft

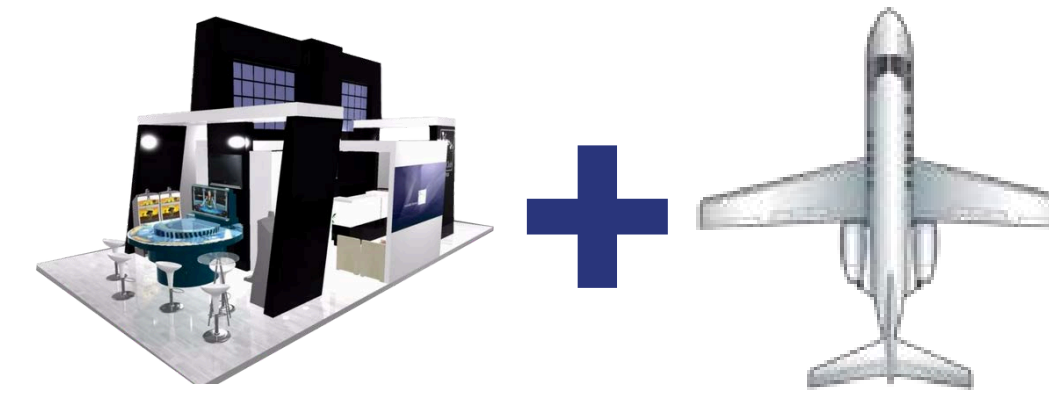

\$8,400 USD

Isle option include:

- Exhibition space in the general zone.
- Monophasic outlet.
- 10 name badges for the exhibitors.

Isles 29.5 x 19.6 ft / 578.2 ft²

Basic Isle



\$10,800 USD

Isle + Aircraft

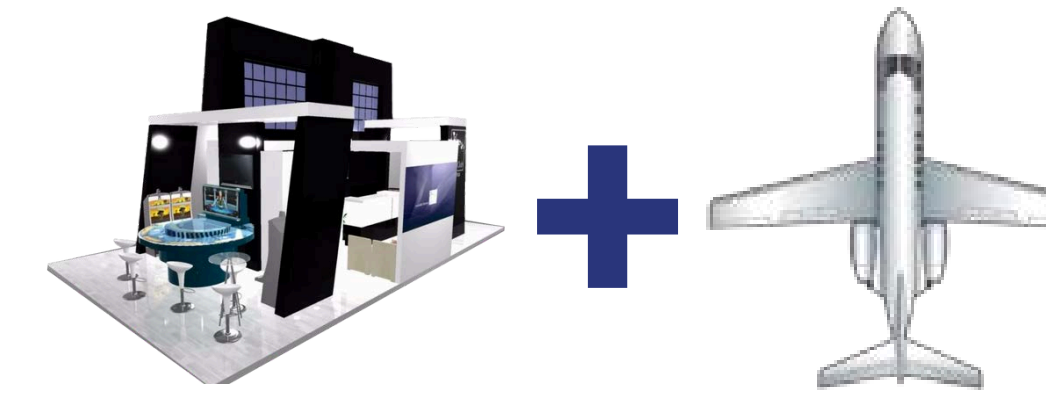

\$12,000 USD

Isle option include:

- Exhibition space in the general zone.
- Monophasic outlet.
- 15 name badges for the exhibitors.

Aircraft*

Without booth

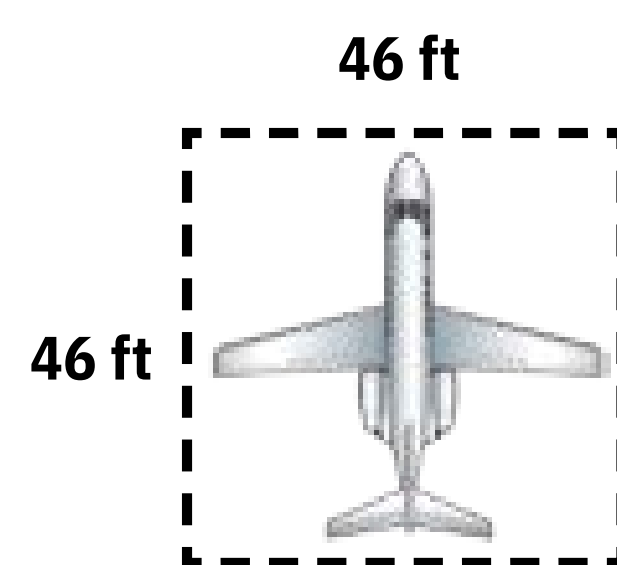

\$4,800 USD

Extra

Applies only for exhibitors with stand or isle contracted.

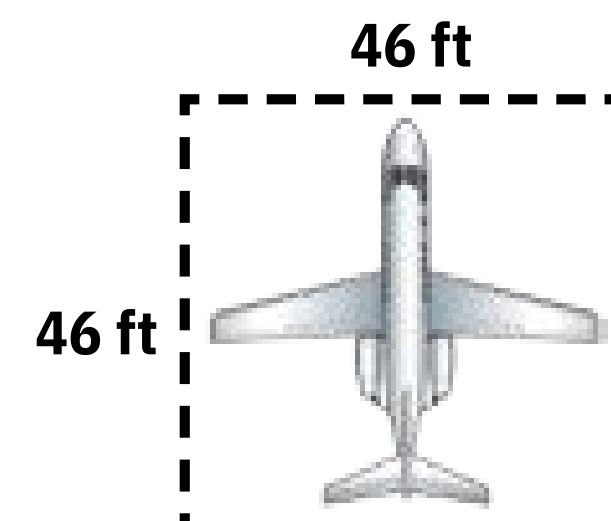

\$1,200 USD

Platform option include:

- Monophasic outlet.
- 10 name badges for the exhibitors.

Two Aircraft

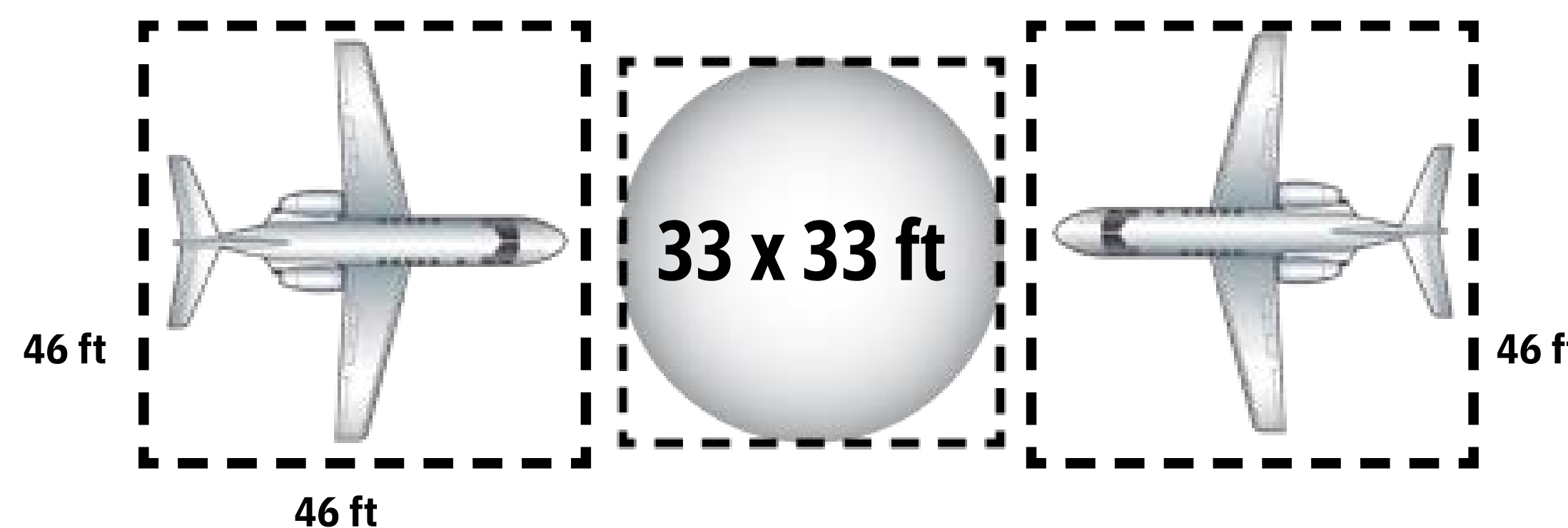

\$8,400 USD

Platform option include:

- Space for two aircraft.
- Space of 33x33 ft. No include Chalet.
- Monophasic outlet.
- 10 name badges for the exhibitors.

Three Aircraft

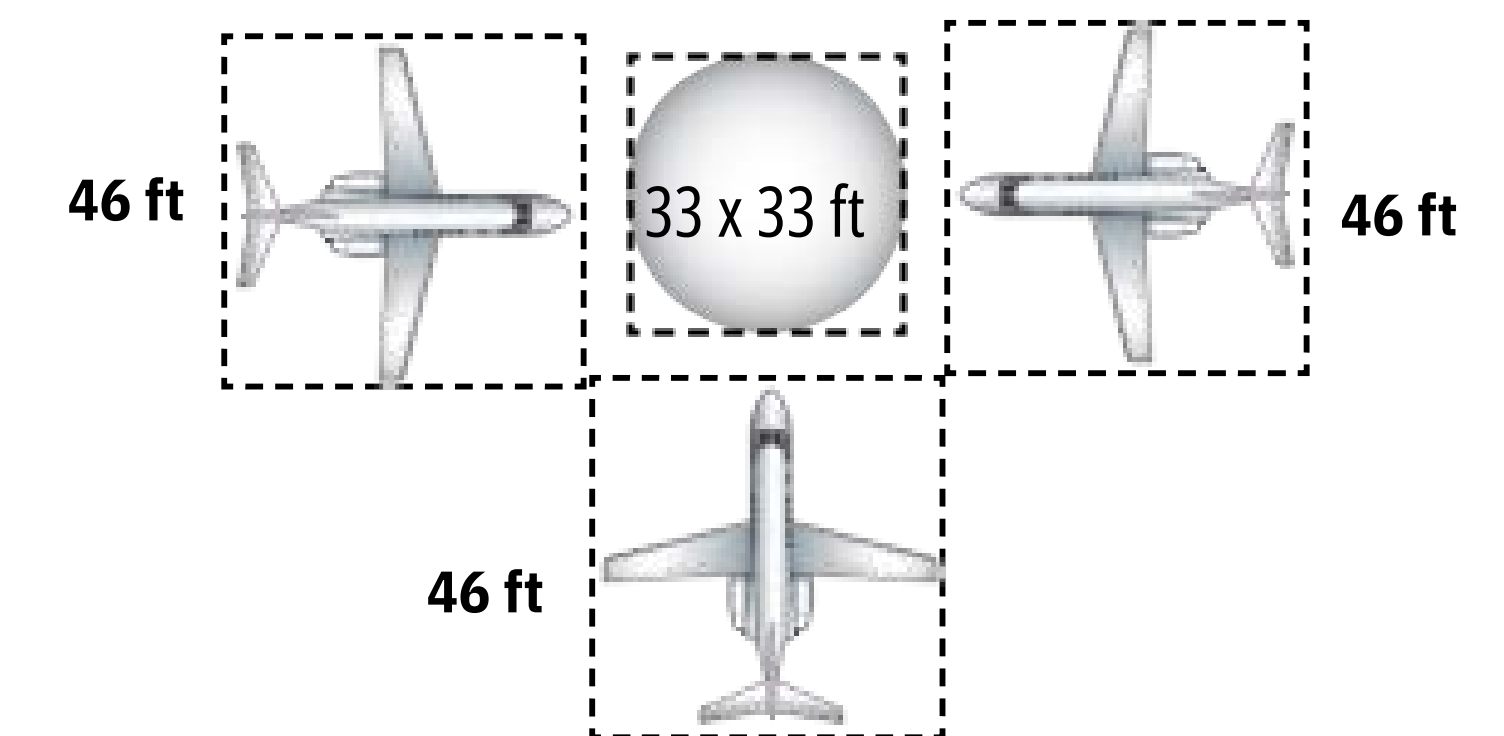

\$12,000 USD

Platform option include:

- Space for three aircraft.
- Space of 33x33 ft. No include Chalet.
- Monophasic outlet.
- 15 name badges for the exhibitors.

* Applies to any vehicles.

NOTE 1: Aircraft with over 46 ft wingspan require two spaces on the platform.

NOTE 2: Ground handling services (movements) generate additional costs. Check exhibitor manual.

Bag



- Your logo will appear on the 12,000 service bags to be distributed during the 3 days of the event.
- This sponsorship will be shared by a maximum of three companies that are not in direct competition.

\$2,600 USD

Floor graphic



- Strategically placed in the exhibition area.

\$600 USD

Sponsorship Lanyard



- Your logo will be displayed on all exclusive AeroExpo lanyards that will be distributed to visitors and exhibitors.
- You will be the only exclusive company to have the benefit of show your brand in 12,000 lanyards which will be circulating around the trade show.

\$8,400 USD

With the support of:



Web page

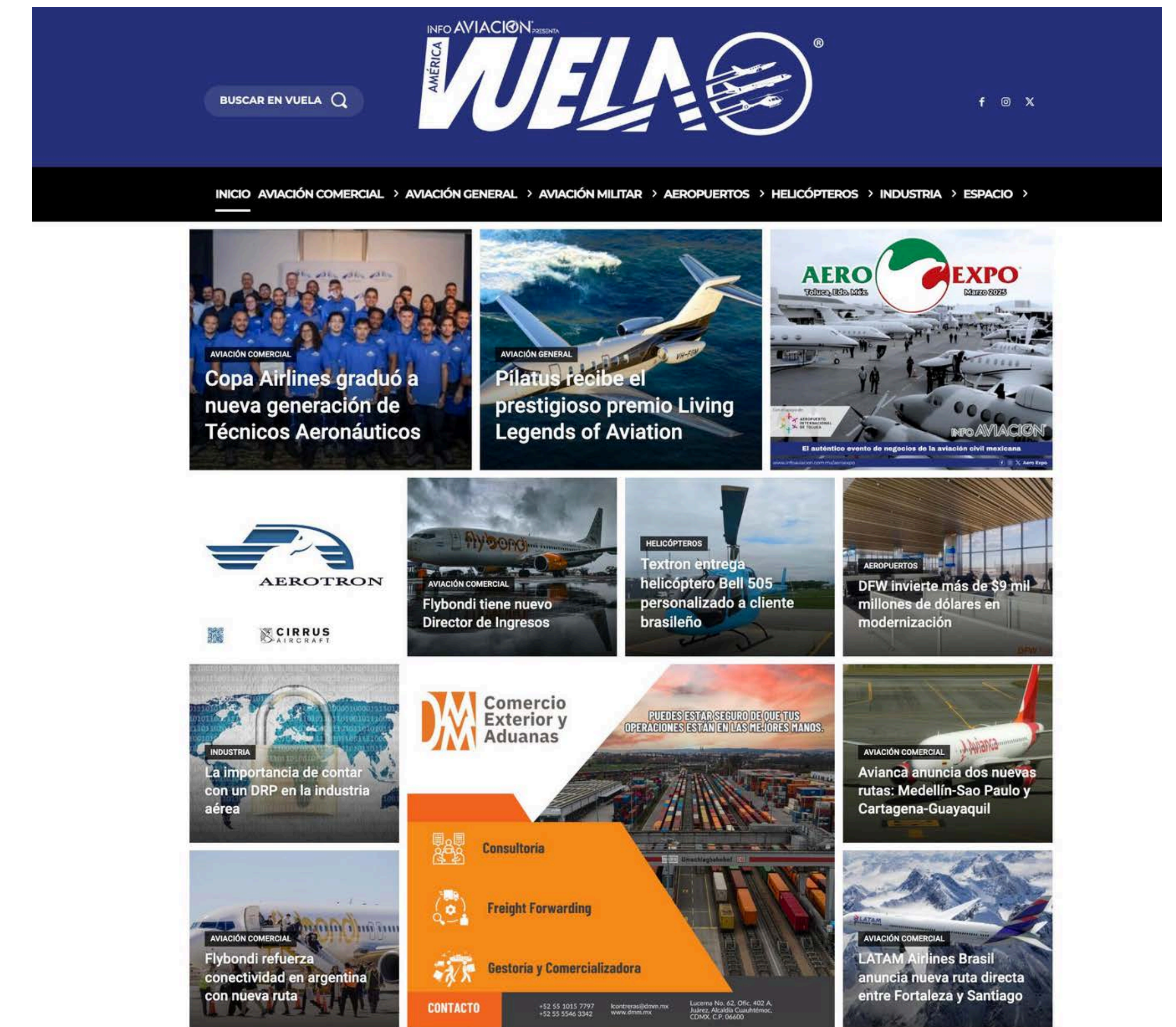

- Distribute your message on América Vuela website (Aero Expo's official media).
- Check spaces and prices with your executive.

Note: Prices subject to change without notice.

For more information: aeroexpo@infoaviacion.com.mx